



Government of West Bengal
Office of the District Land & Land Reforms Officer
Paschim Medinipur

At- Keranitola, P.O.- Midnapur, Dist.- Paschim Medinipur, Pin- 721101
Email ID- dilro.mid@gmail.com / report.admir@gmail.com



No: 40

Dated: 08.03.22

Notice Inviting Quotation No. 1 of 2021-22

Sealed Quotations in prescribed format are invited from the original owner/ supplier construction / bona fide contractor for the work "Supplying of Concrete boundary Pillar using concrete not leaner than (1:1.5:3) nominal mix and steel as per requirement and fixing the same at suitable location along the border of state of West Bengal and Odisha along River Subarnarekha in Block- Dantan-I, P.S.- Dantan as per attached drawing and direction of D.L.& L.R.O., Paschim Midnapore District by the office of the District Land & Land Reforms Officer.

The Quotation will be received by the undersigned on behalf of the Additional District Magistrate & District Land & Land Reforms Officer, Paschim Medinipur up to 4.00 p.m. on 15.03.2022 and will be opened at 4-30 p.m. on the same day in presence of the participants or their authorized representative.

Quotation paper consisting of the schedule and terms & conditions will be available from the office of the undersigned free of cost during office hours of any working day up to 14.03.2022 on submission of application.

The rate to be quoted both in words and in figure. The accepting authority/ Additional District Magistrate & District Land & Land Reforms Officer reserves the right to accept and or reject any or all the quotations for which no clarification will be given to the quotation.

The quotation will be valid for one year.



Additional District Magistrate &
District Land & Land Reforms Officer
Paschim Medinipur

Dated: 08.03.22

Memo No: 1534(19)

Copy submitted / forwarded for information and wide Circulation to the:-

- 1) The Additional District Magistrate (Gen) / (Dev) / (P) / (ZP), Paschim Medinipur.
- 2) The Sub-Divisional Officer, Sadar
- 3) The Sub-Divisional Officer, Kharagpur.
- 4) The Executive Engineer, West Midnapore Division, (I. & W. Dte.), Paschim Medinipur.
- 5) The Executive Engineer, West Midnapore Division, (PWD), Paschim Medinipur.
- 6) The Shabhapati Dantan-I, Panchyat Samiti, Paschim Medinipur.
- 7) The Block Development Officer, Dantan-I, Paschim Medinipur.
- 8) The Block Land & Land Reforms Officer, Dantan - I, Paschim Medinipur
- 9) The District Information Coordination Officer, Paschim Medinipur for wide publication in District Website.
- 10) The Officer - in - Charge Computer of this office for wide publication in Website.
- 11) The Officer - in - Charge Establishment / M.M. of this office.
- 12) CA to the District Magistrate, Paschim Medinipur for appraisal.
- 13) CA to the Shabhadhipati, Paschim Medinipur Zilla Parishad
- 14) CA to the Additional District Magistrate (LR), Paschim Medinipur
- 15) Office notice board.



Additional District Magistrate &
District Land & Land Reforms Officer
Paschim Medinipur

Terms & Conditions:

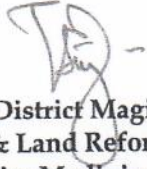
- 1) The quotationers shall quote the rate both in words and figures.
- 2) All rates quoted are to be inclusive of all charges.
- 3) No conditional quotation will be accepted by the accepting authority and the authority has every right to reject the quotation without showing any reason.
- 4) The work should be completed with in 30(thirty) days from the date of issuing of work order.
- 5) **The Additional District Magistrate & District Land & Land Reforms Officer Paschim Medinipur** is the Officer-in-Charge. The quotationer shall have to execute the work as per specification of the schedule without any further additional claim to the **Additional District Magistrate**
- 6) Trade License / Pan Card / Bank account details with IFSC code / GST registration number to be submitted.
- 7) The authority reserves the right to distribute the supply order among the successful quotationers in the interest of speedy and smooth disposal of supply maintaining the interest of the Government.
- 8) The cost of carriage of materials will be born by the quotationers.
- 9) Any defected material, if found should be replace by him on his own cost within 7 days.

**Additional District Magistrate &
District Land & Land Reforms Officer
Paschim Medinipur**

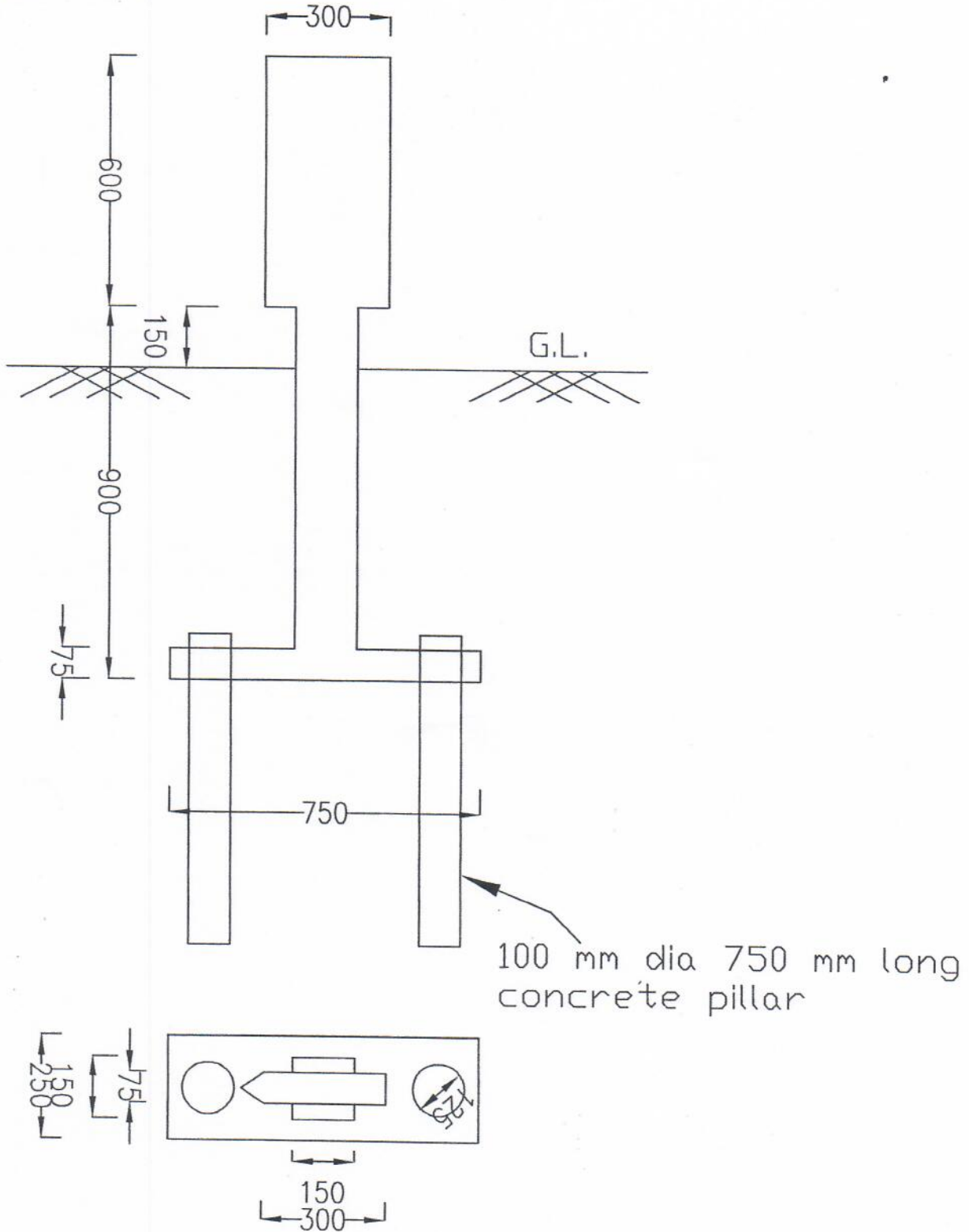
Name of Work:- "Supplying of Concrete boundary Pillar using concrete not leaner than (1:1.5:3) nominal mix and steel as per requirement and fitting and fixing the same at suitable location along the border of state of West Bengal and Odisha along River Subarnarekha in Block Datan-I, P.S.-Datan as per attached drawing and direction of BLRE, West Midnapore District."



100 mm dia 750 mm long concrete pillar

DRAWING OF BOUNDARY PILLAR

Sectional Officer
Anicut (Hd. Qr) Section

8/2/22



Government of West Bengal
Office of the District Land & Land Reforms Officer
Paschim Medinipur
At- Keranitola, P.O.- Midnapur, Dist.- Paschim Medinipur, Pin- 721101
Email ID- dilro.mid@gmail.com / report.admir@gmail.com

Proforma for Quotation

Sl. No.	Description of work	Quantity	Unit	Rate	Amount Rs.
1	Supplying of Concrete boundary Pillar using concrete not leaner than (1:1.5:3) nominal mix and steel as per requirement and fitting the same at suitable location along the border of state of West Bengal and Odisha along River Subamarekha in Block- Dantan-I, P.S.-Dantan as per attached drawing and direction of DLRO, West Midnapore District.”	40 Nos	Each		

(Rate is inclusive of all charges including GST)

Total Amount:

(In words.....)

(Signature of Bidder)